

ANIVI

Experts processing

ANIVI

Some data

- Founded at Bilbao in the thirties
- Factory of 12.500 m²
- Work force of 80 persons
- Near to the Bilbao's harbour and airport
- Design and manufacturing of capital goods for mineral and chemicals processing





Technical office

- Own design
- Modern software
- Most modern technology

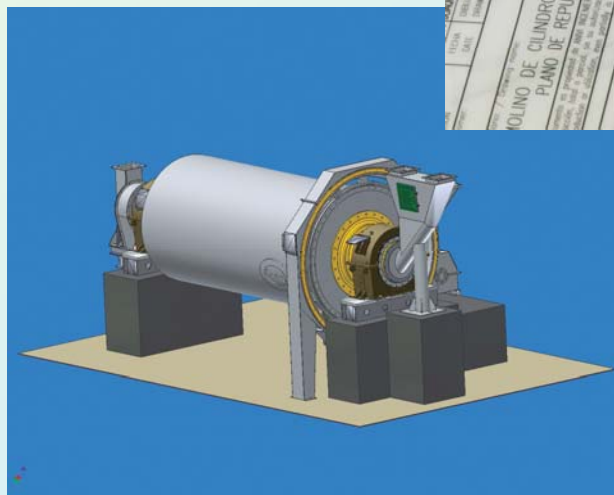
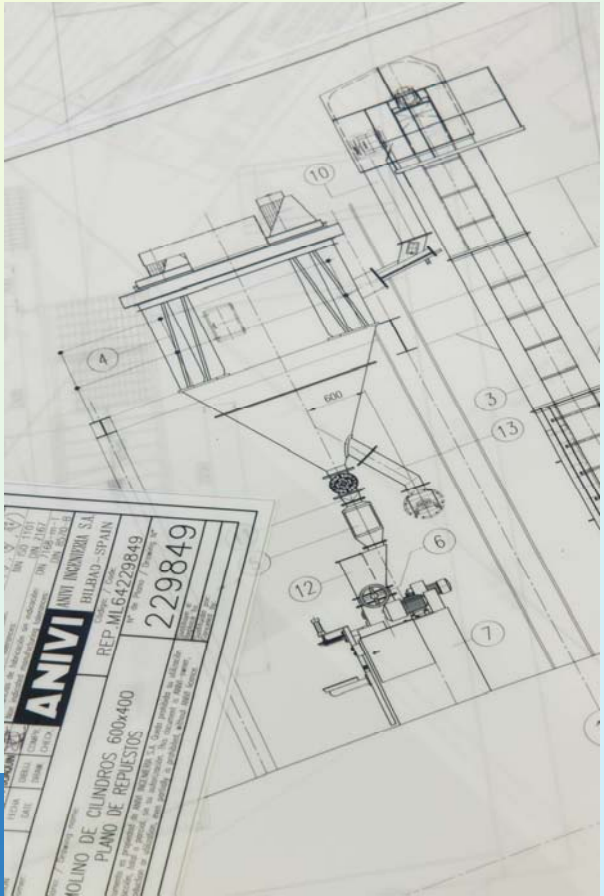



Manufacturing

- Complete lines for machining big parts
- Most skilled team
- Great experience





Investigation R+D

- Laboratory equipped with the best technology
- Pilot plants for semindustrial tests
- Continuous improvement of products and processes

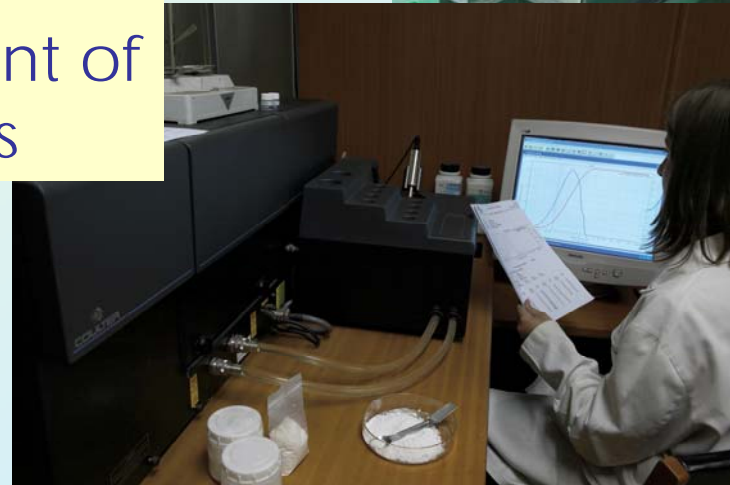

ANIVI

DIVISION



Grinding and clasification

- Ball and rod mills
- Roller mills
- NSA and Centriconic classyfiers
- Complete processing plants



ANIVI

DIVISION

Grinding and clasification



ANIVI

DIVISION

Drying and calcination

- Rotary dryers single and double pass
- Direct and indirect rotary kilns
- All fuels can be used
- Fluid beds

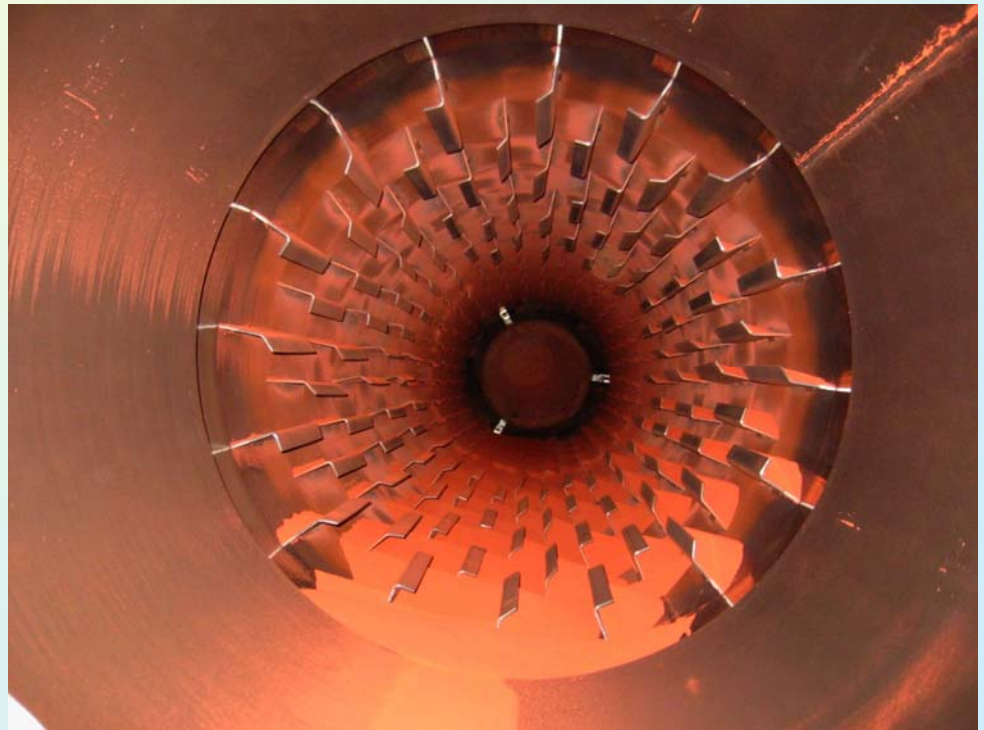



DIVISION

Drying and calcination



ANIVI

DIVISION

Air and Gases

- Centrifugal fans
- Bag filters
- Scrubbers
- Complete plants to reduce emissions



ANIVI

DIVISION

Air and Gases

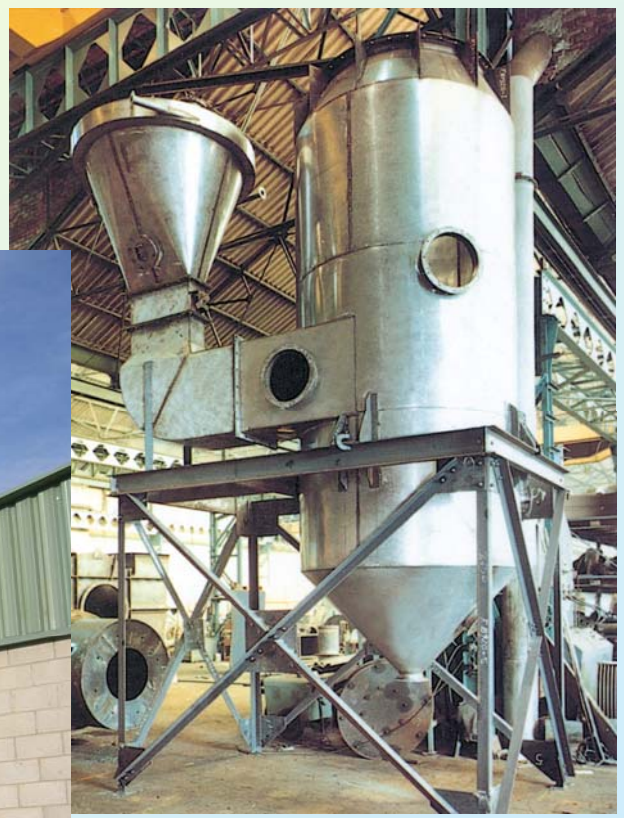



ANIVI INGENIERIA,S.A.

Avenida Chorierra, 8

48180 LOIU (VIZCAYA) SPAIN

Tel. +34 94 4531900

Fax. + 34 94 4532175

E-mail: info@anivi.com

Website: www.anivi.com